

Appendix E
York Water System Flows

Figure E.1-2006

York Water System Flows
2006 Max Day Scenario

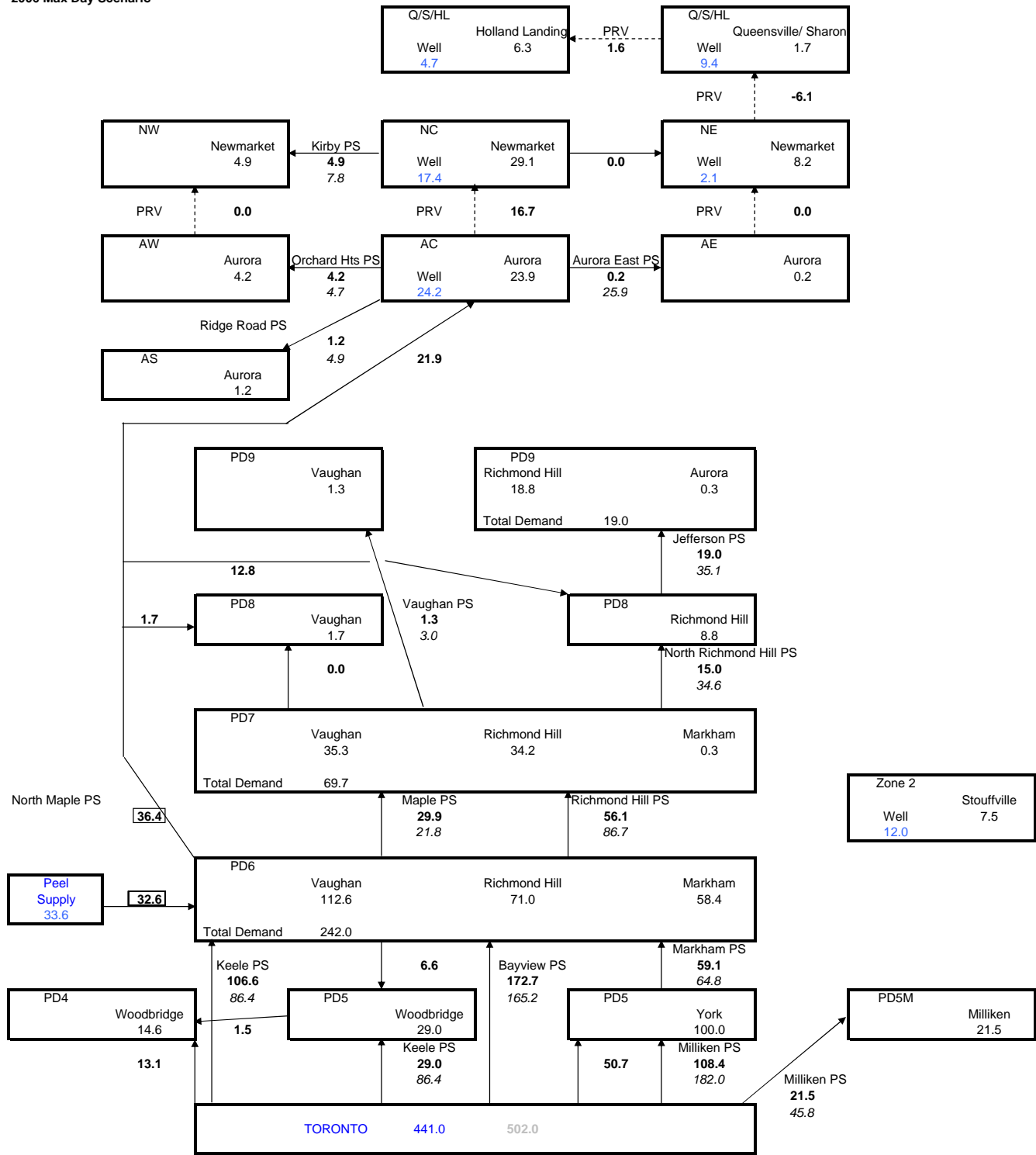

Numbers in italics - current pumping station capacities
Numbers in box - pumping station capacity upgrade required

Figure E.1-2011

York Water System Flows
2011 Max Day Scenario

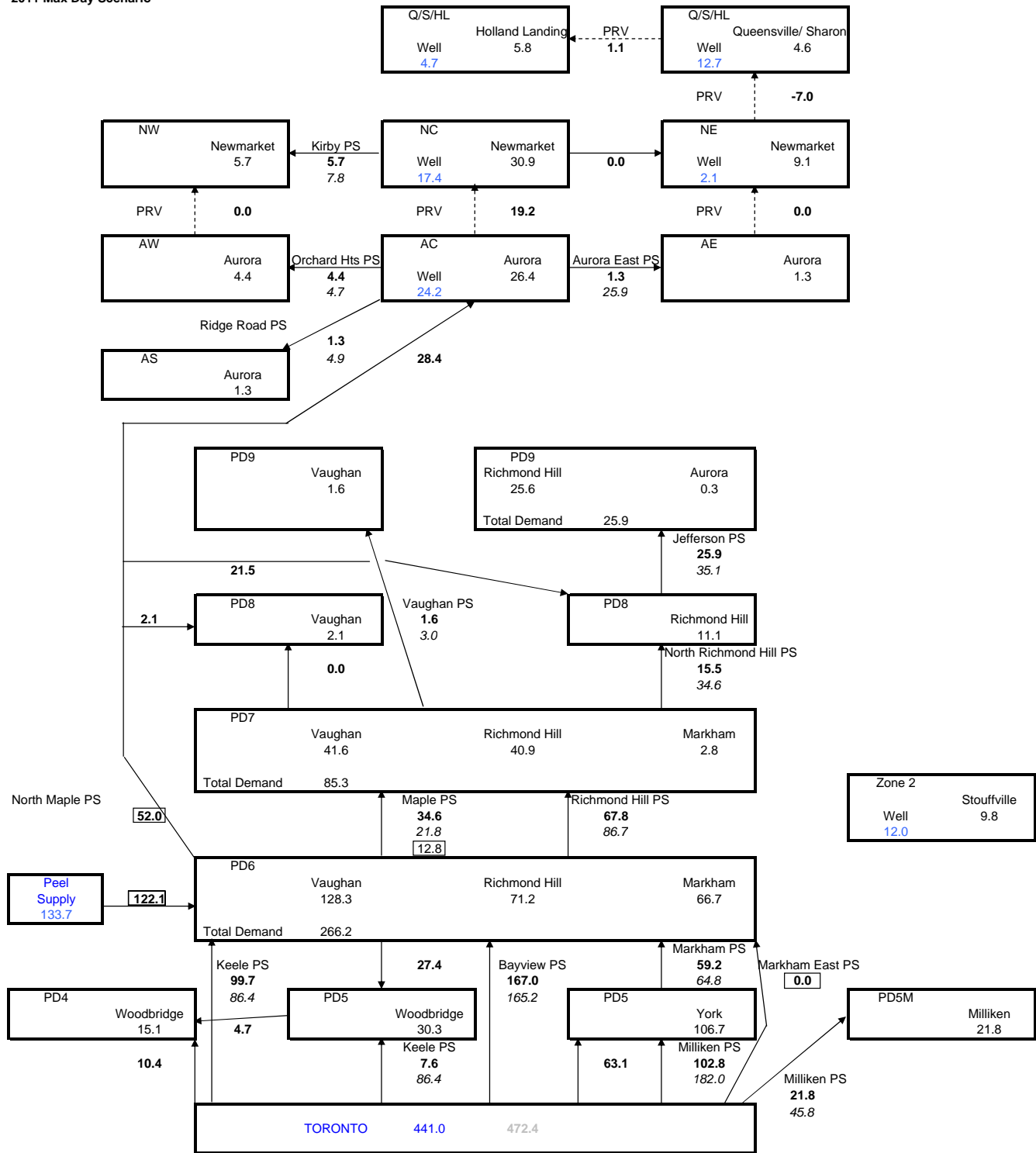

Numbers in italics - current pumping station capacities
Numbers in box - pumping station capacity upgrade required

Figure E.1-2016

York Water System Flows
2016 Max Day Scenario

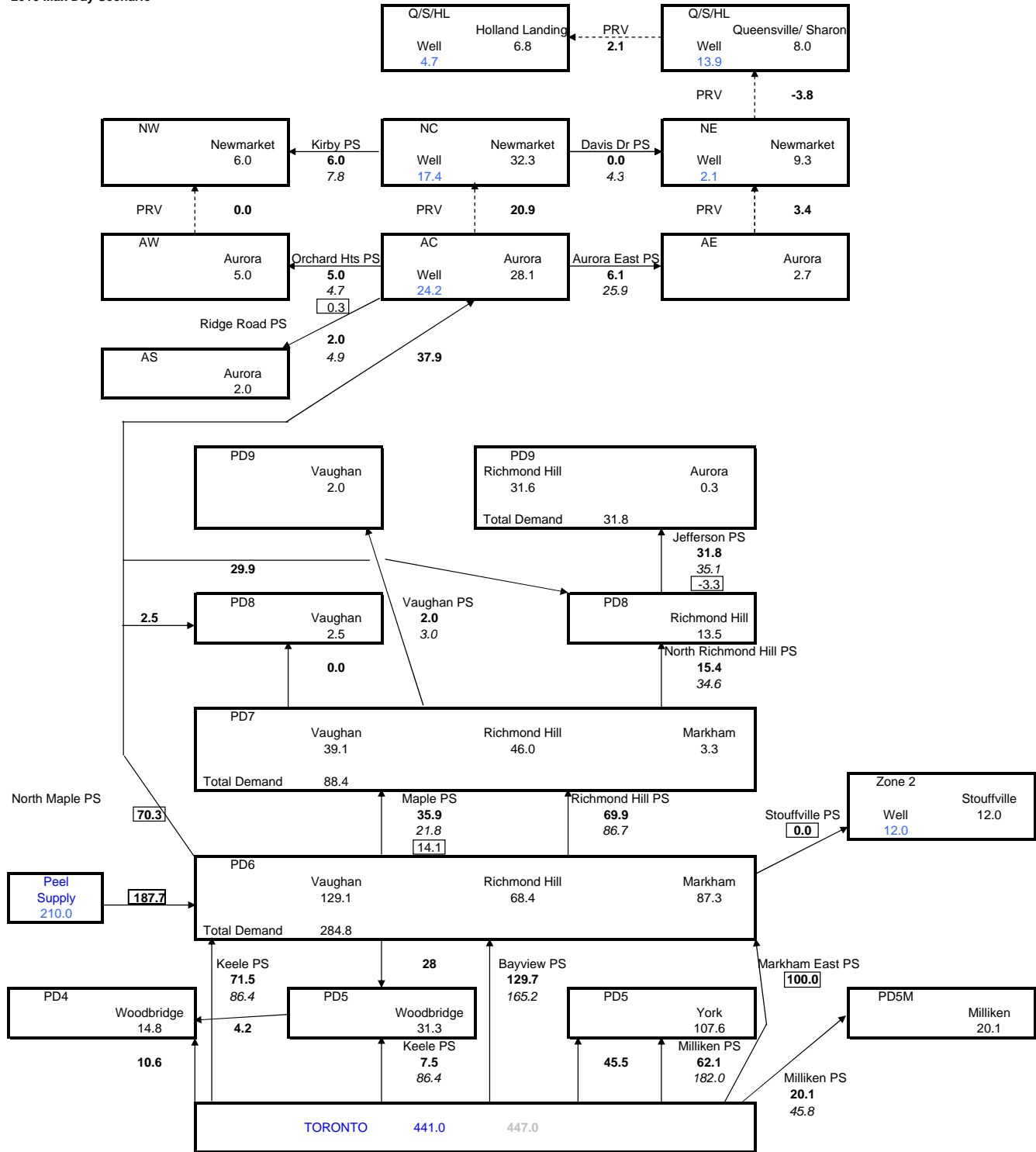

Numbers in italics - current pumping station capacities
Numbers in box - pumping station capacity upgrade required

Figure E.1-2026

York Water System Flows
2026 Max Day Scenario

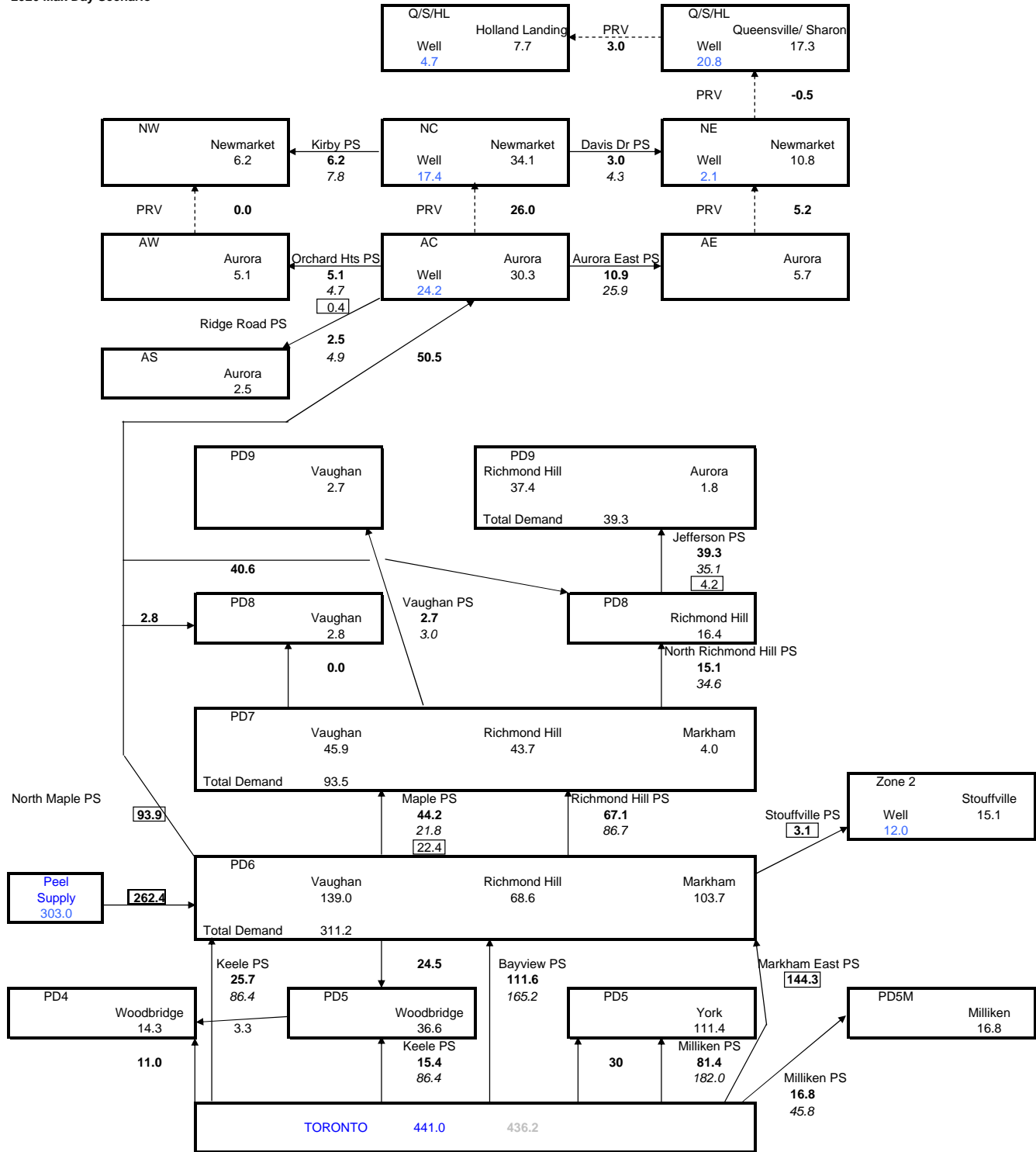

Numbers in italics - current pumping station capacities
Numbers in box - pumping station capacity upgrade required

Figure E.1-2036

York Water System Flows
2036 Max Day Scenario

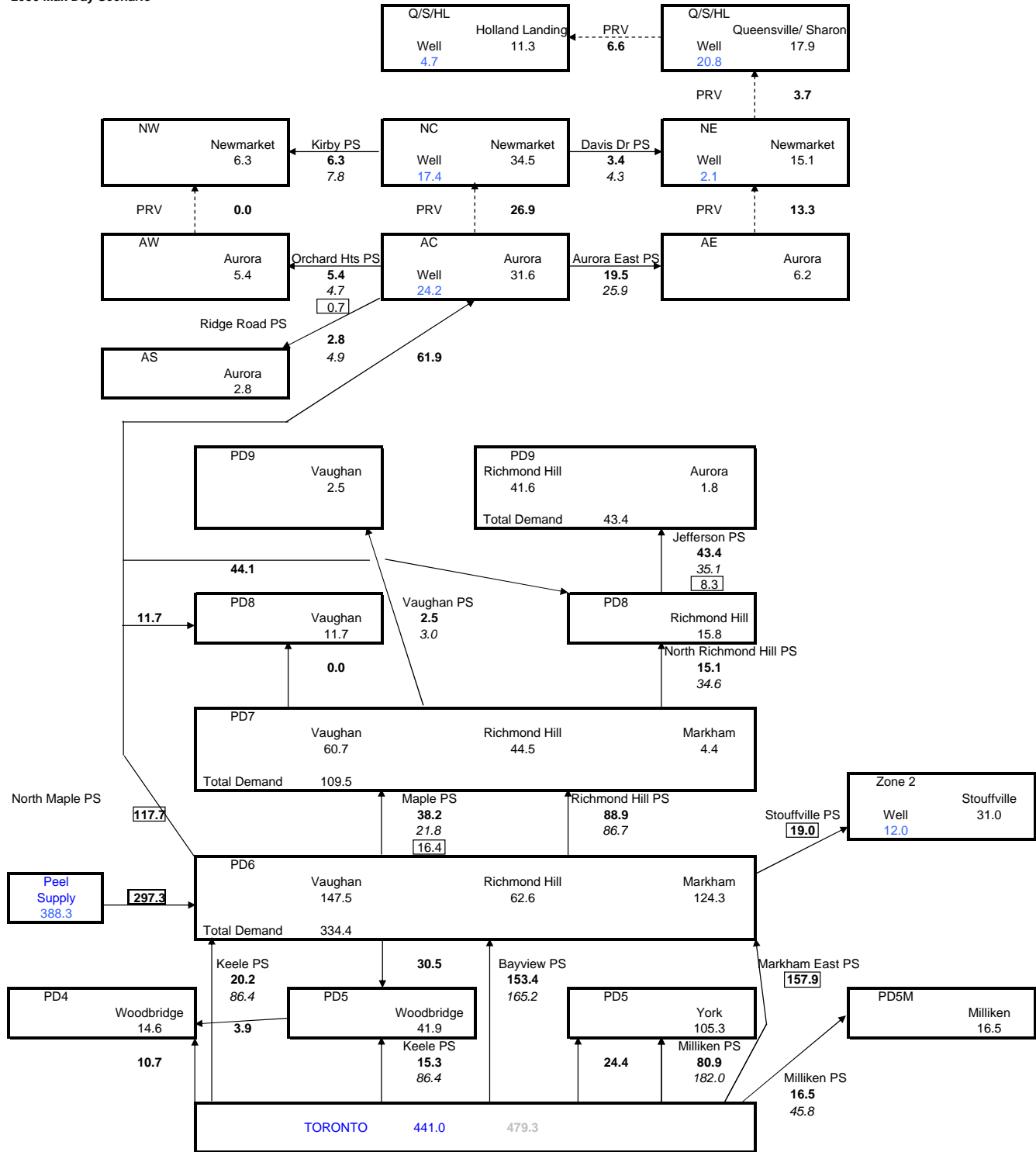

Numbers in italics - current pumping station capacities
Numbers in box - pumping station capacity upgrade required

York Water System Flows
2006 Average Day Scenario

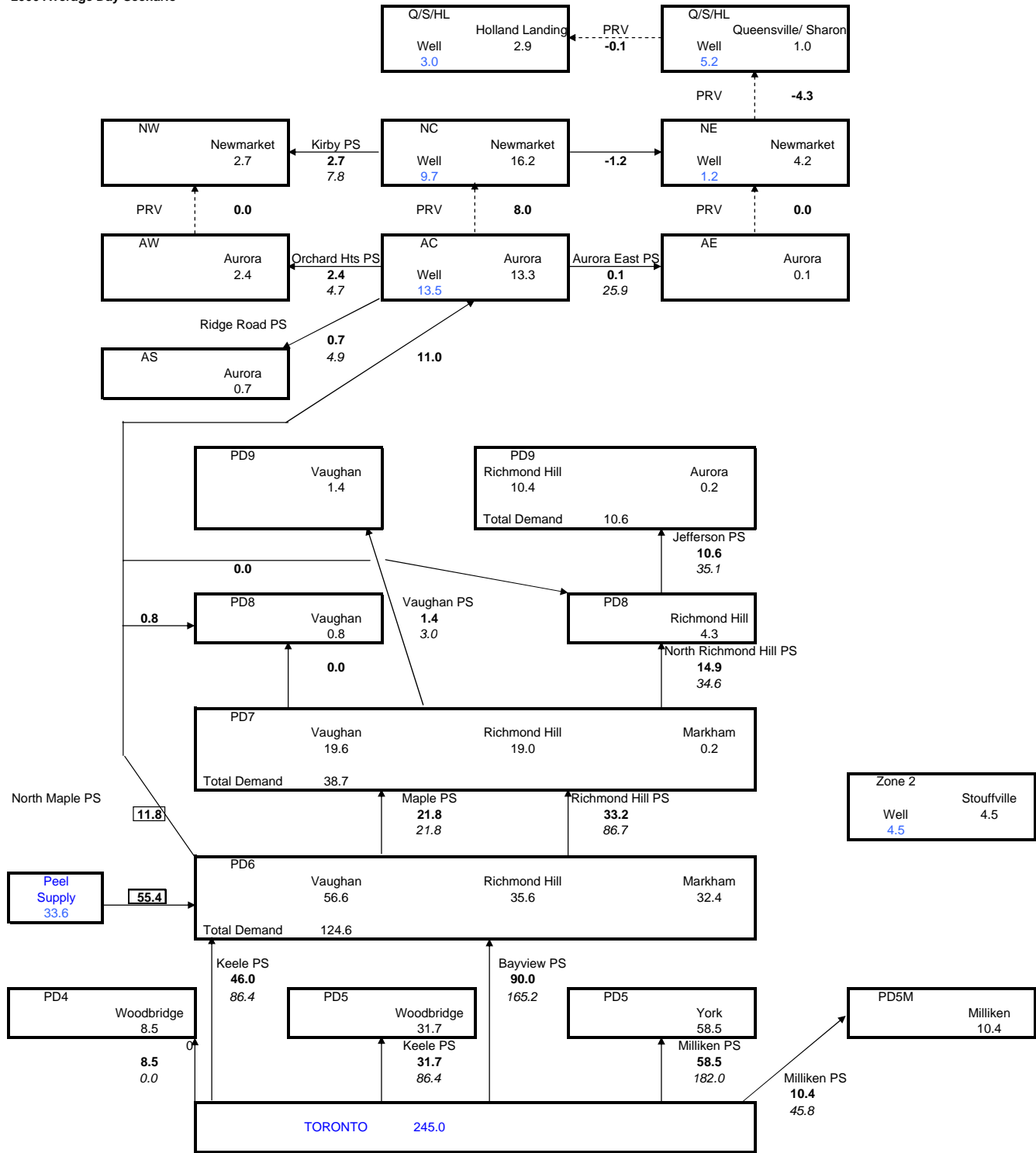

Numbers in italics - current pumping station capacities
Numbers in box - pumping station capacity upgrade required

York Water System Flows
2011 Average Day Scenario

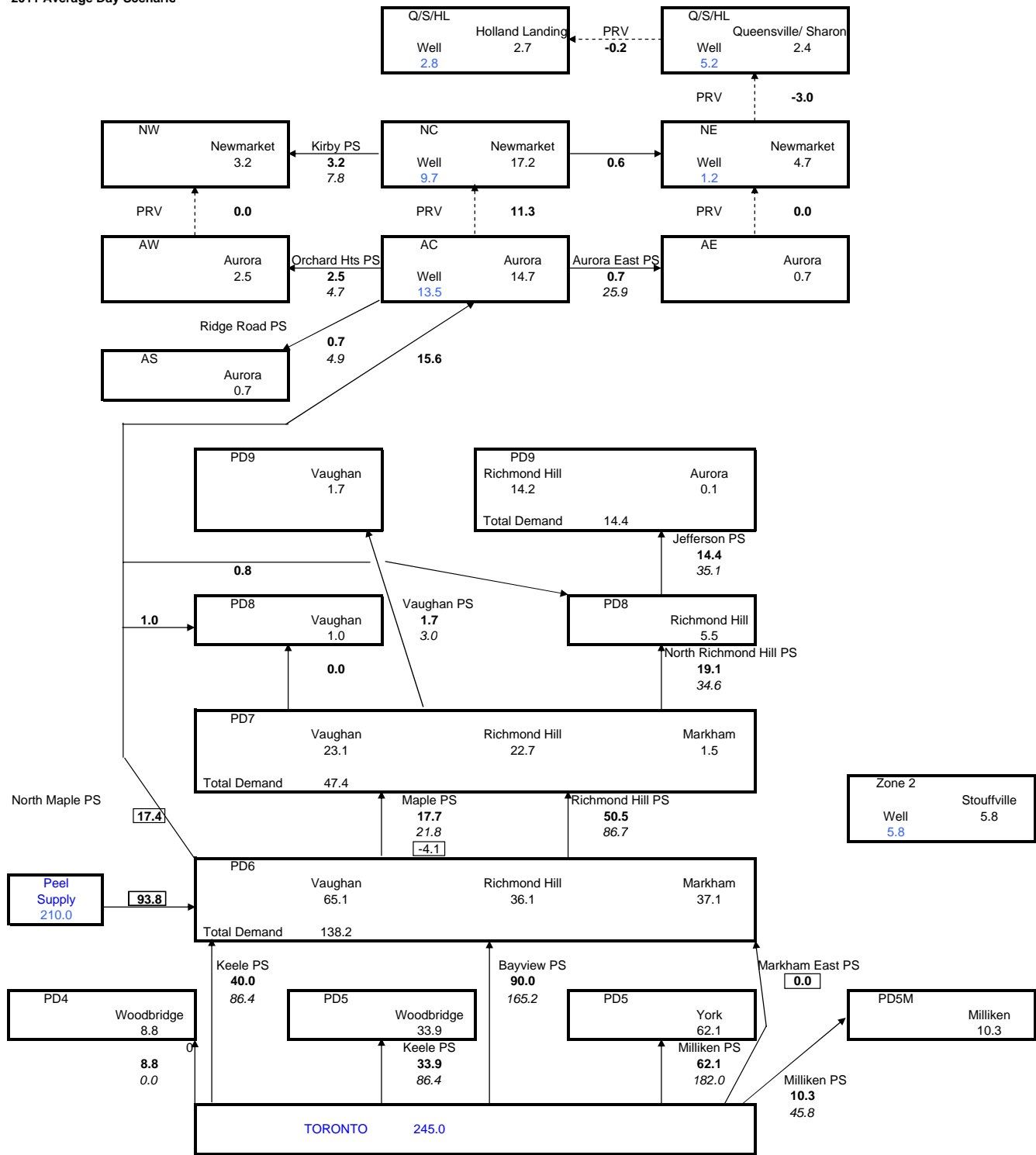

Numbers in italics - current pumping station capacities
Numbers in box - pumping station capacity upgrade required

York Water System Flows
2016 Average Day Scenario

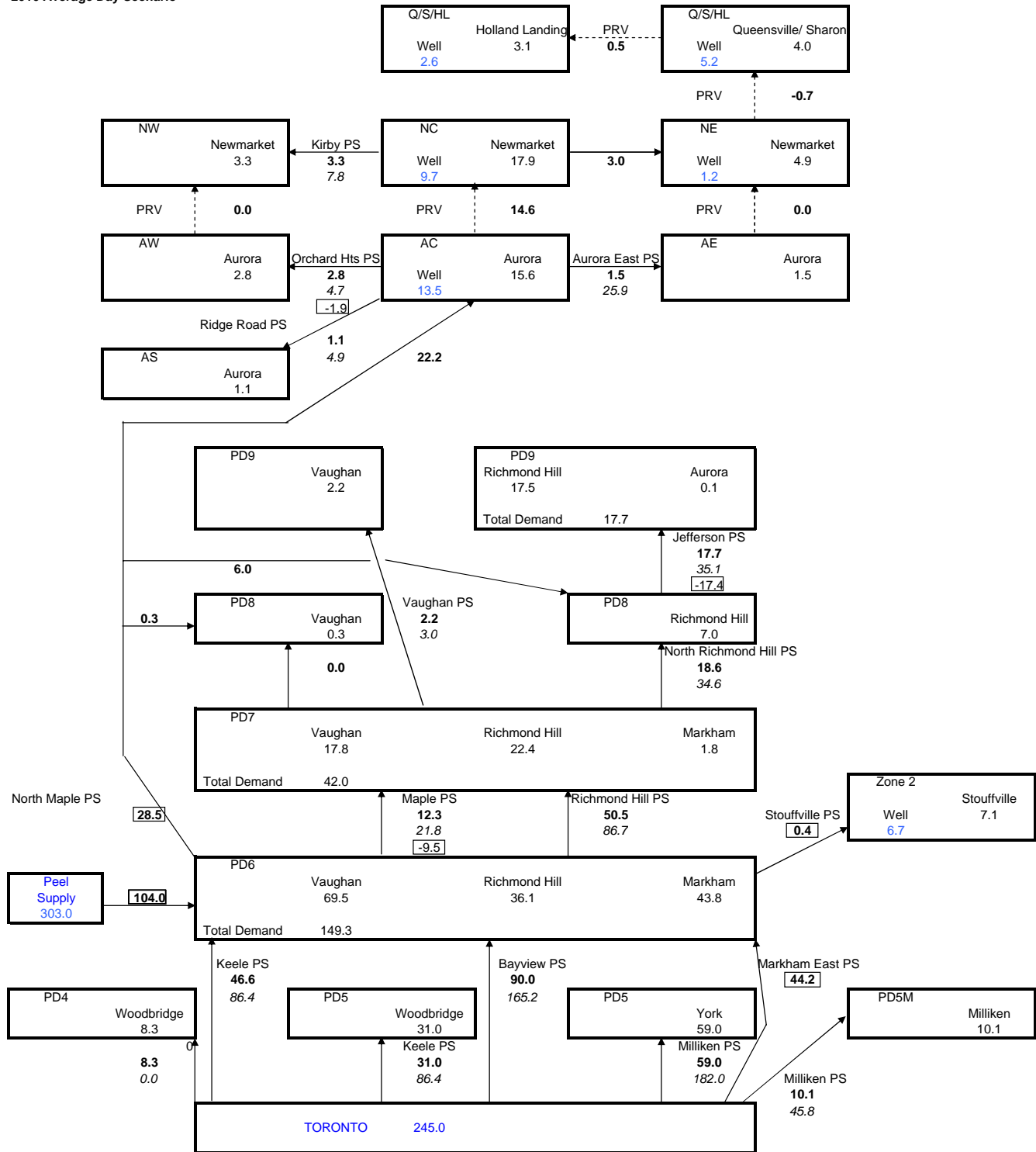

Numbers in italics - current pumping station capacities
Numbers in box - pumping station capacity upgrade required

York Water System Flows
2026 Average Day Scenario

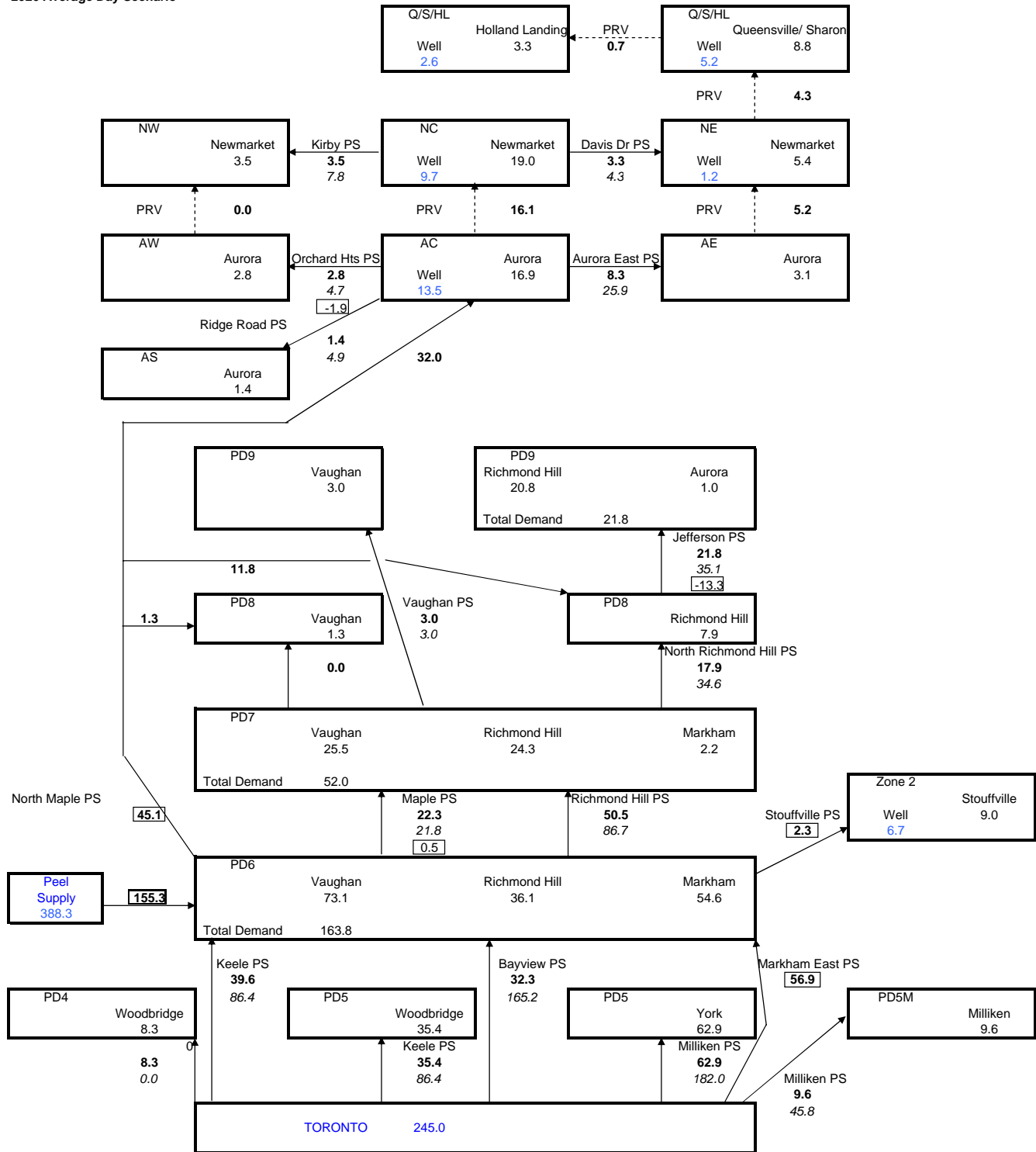

Numbers in italics - current pumping station capacities
Numbers in box - pumping station capacity upgrade required

York Water System Flows
2036 Average Day Scenario

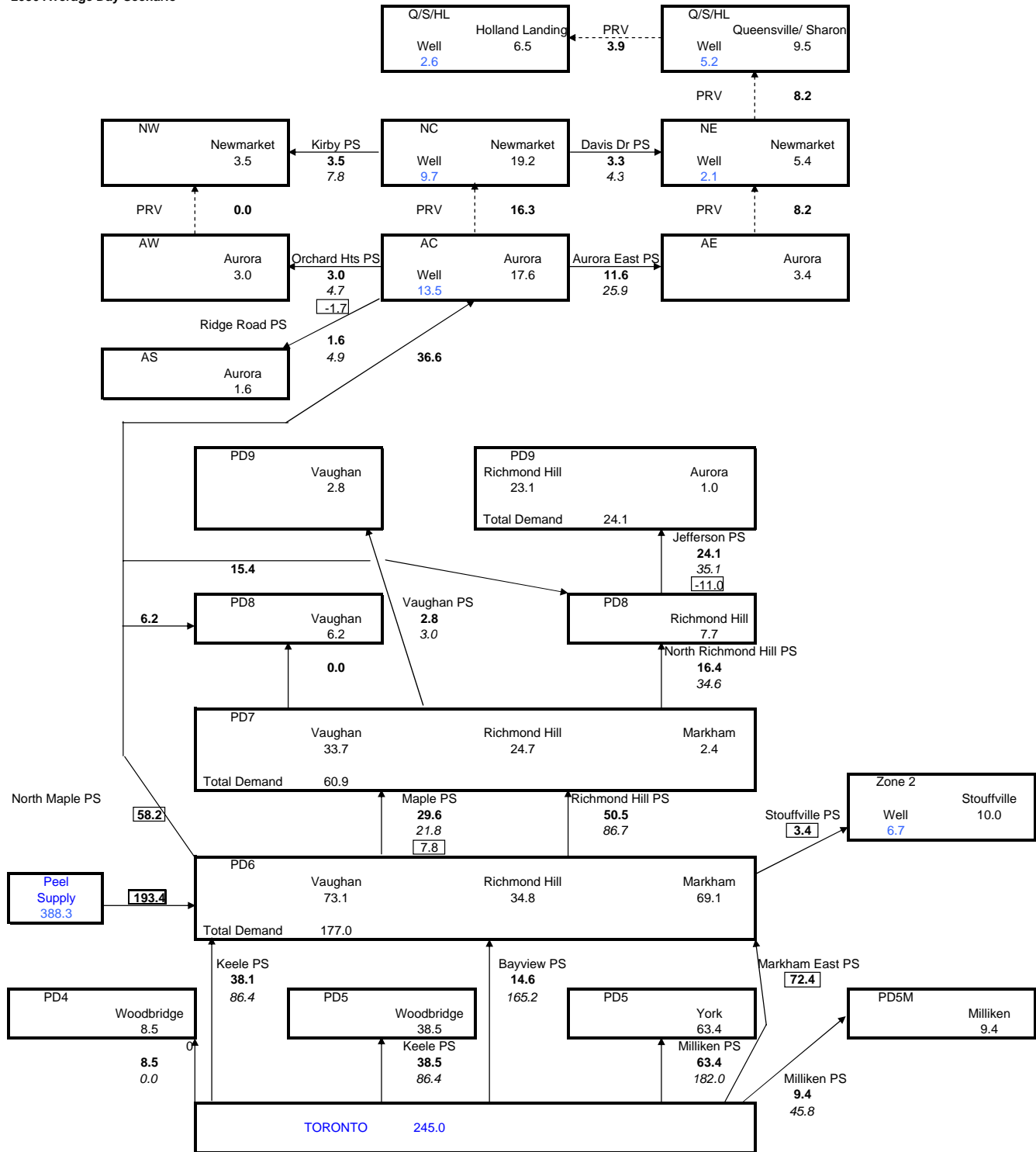

Numbers in italics - current pumping station capacities
Numbers in box - pumping station capacity upgrade required

York Water System Flows
2006 Max Day Scenario

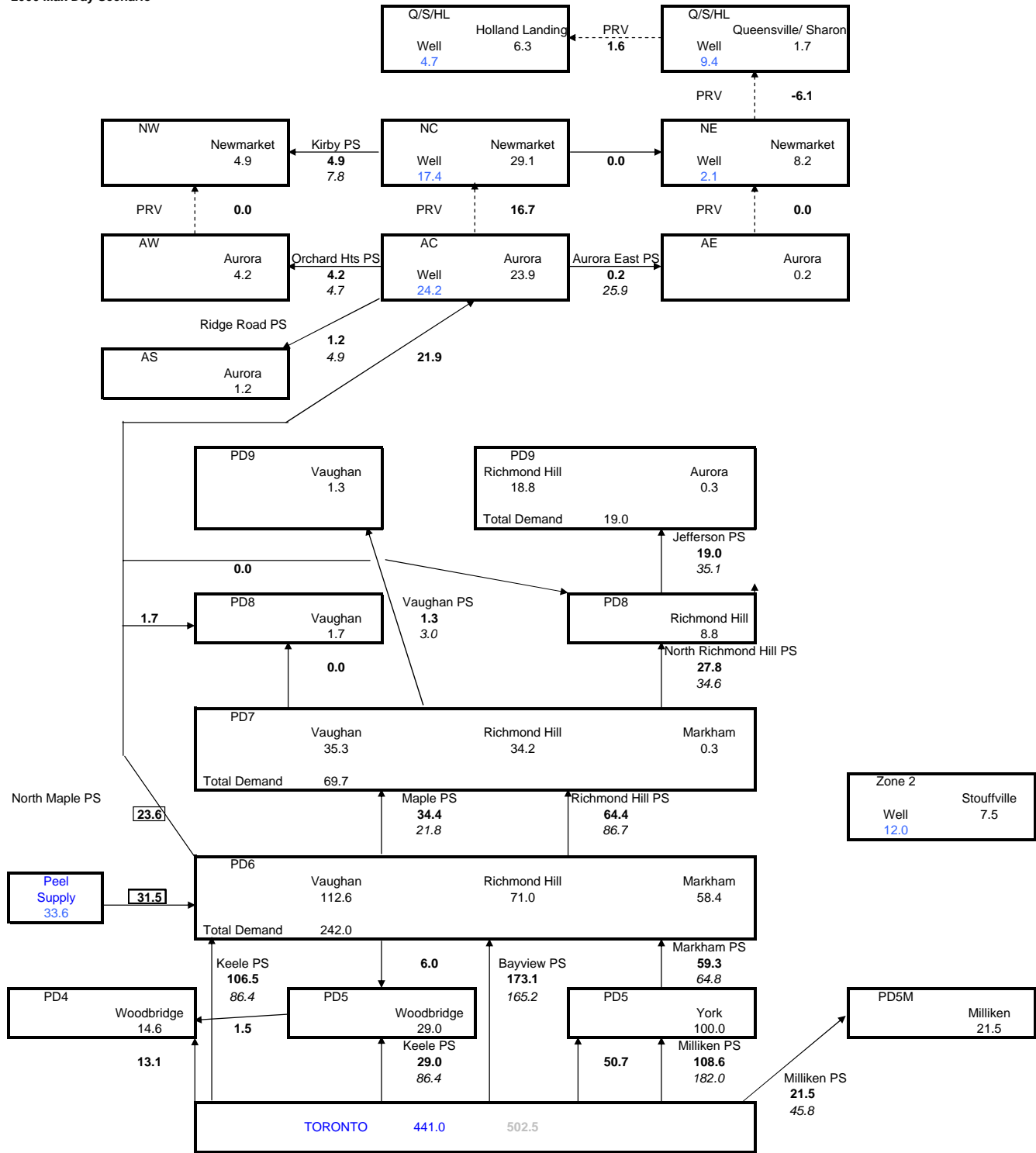

Numbers in italics - current pumping station capacities
Numbers in box - pumping station capacity upgrade required

York Water System Flows
2011 Max Day Scenario

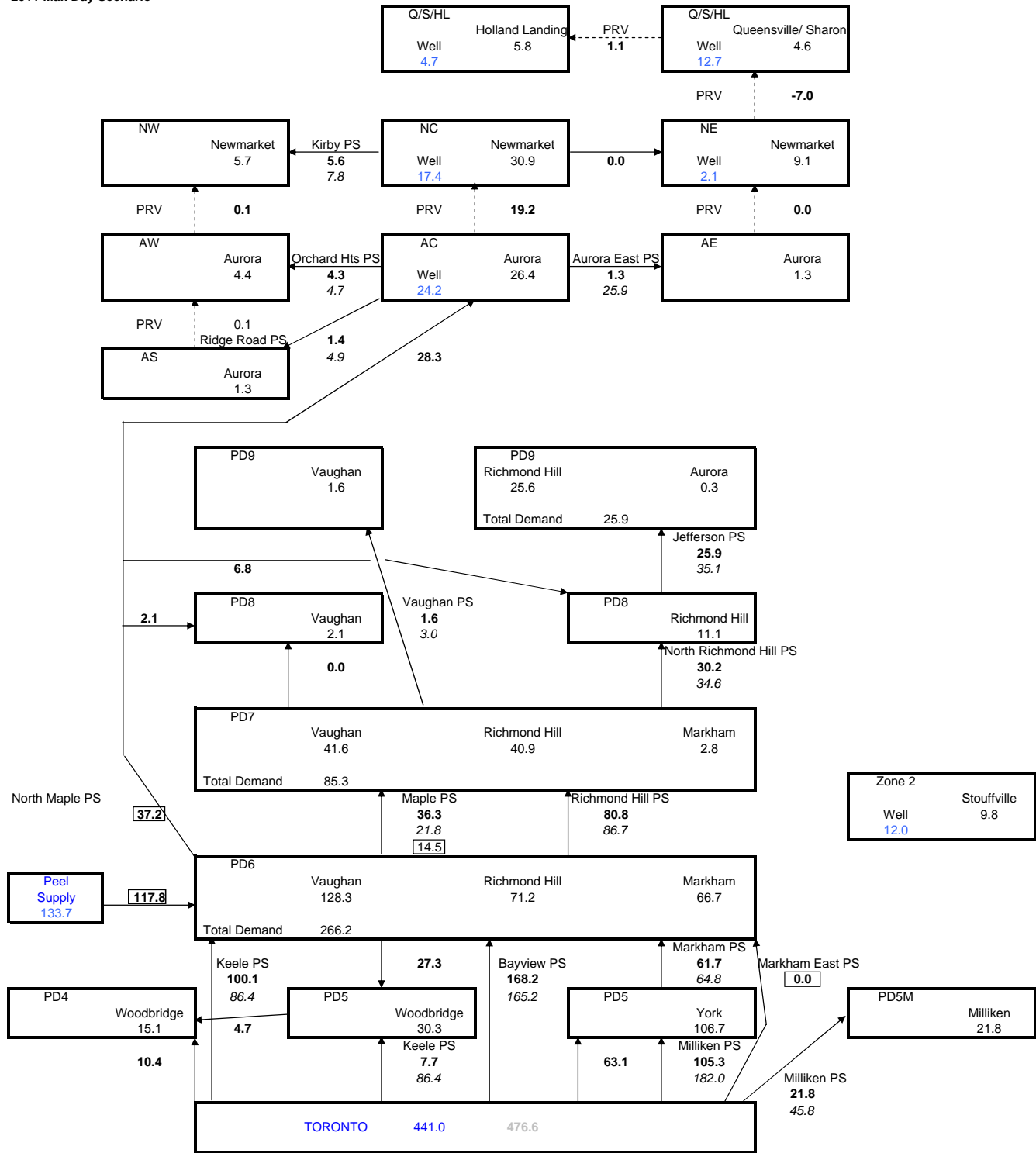

Numbers in italics - current pumping station capacities
Numbers in box - pumping station capacity upgrade required

York Water System Flows
2016 Max Day Scenario

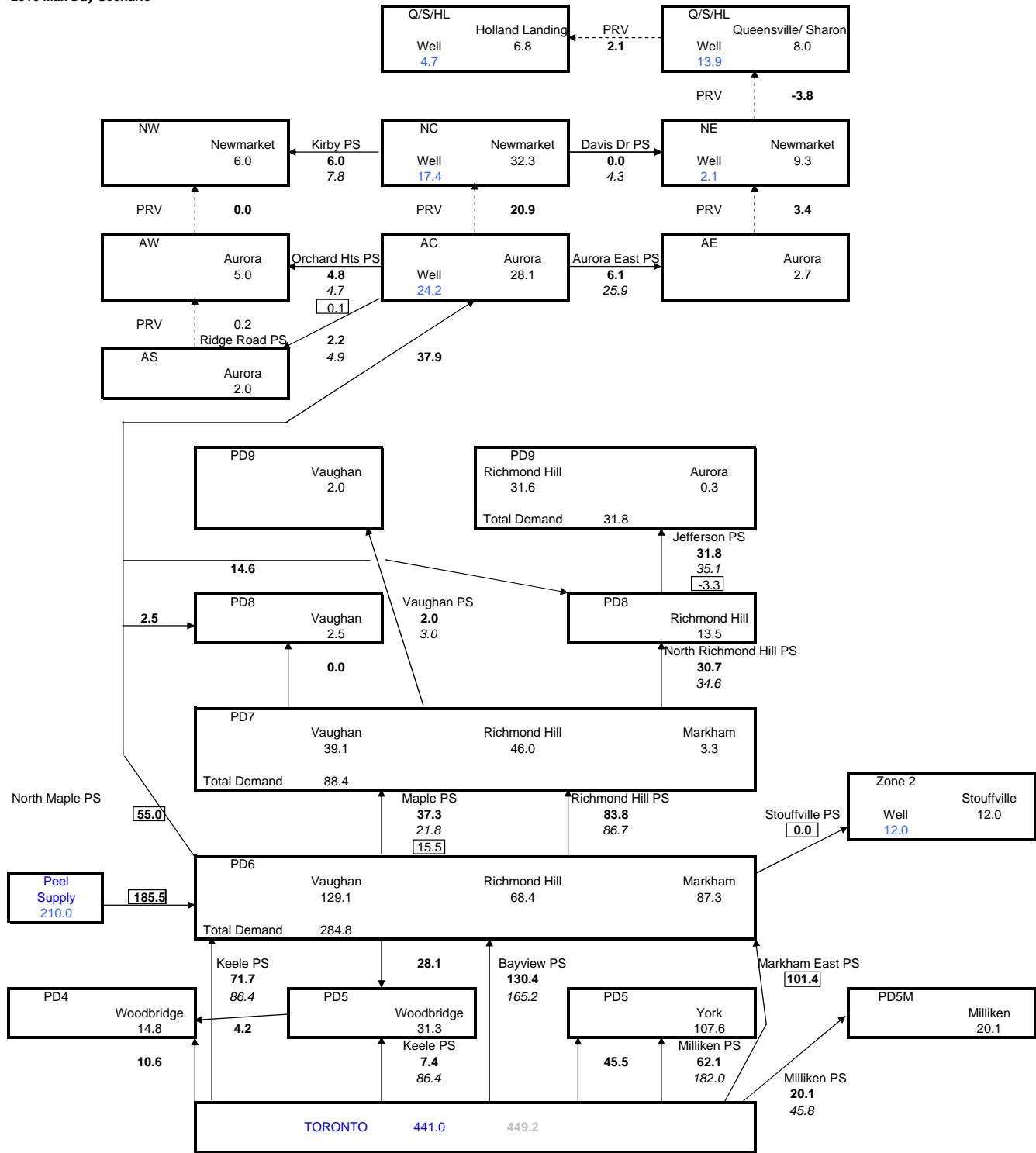

Numbers in italics - current pumping station capacities
Numbers in box - pumping station capacity upgrade required

York Water System Flows
2026 Max Day Scenario

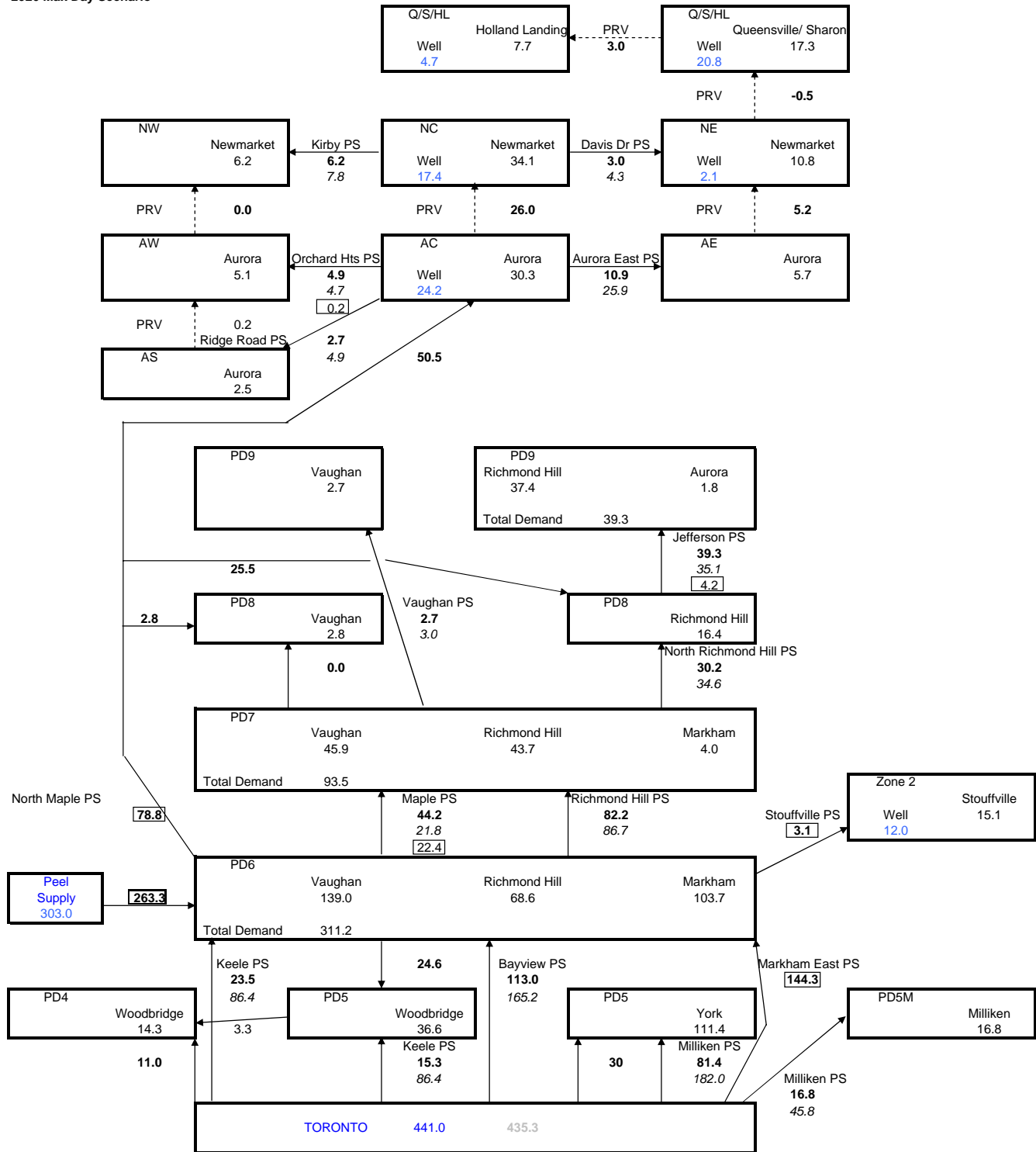

Numbers in italics - current pumping station capacities
Numbers in box - pumping station capacity upgrade required

York Water System Flows
2036 Max Day Scenario

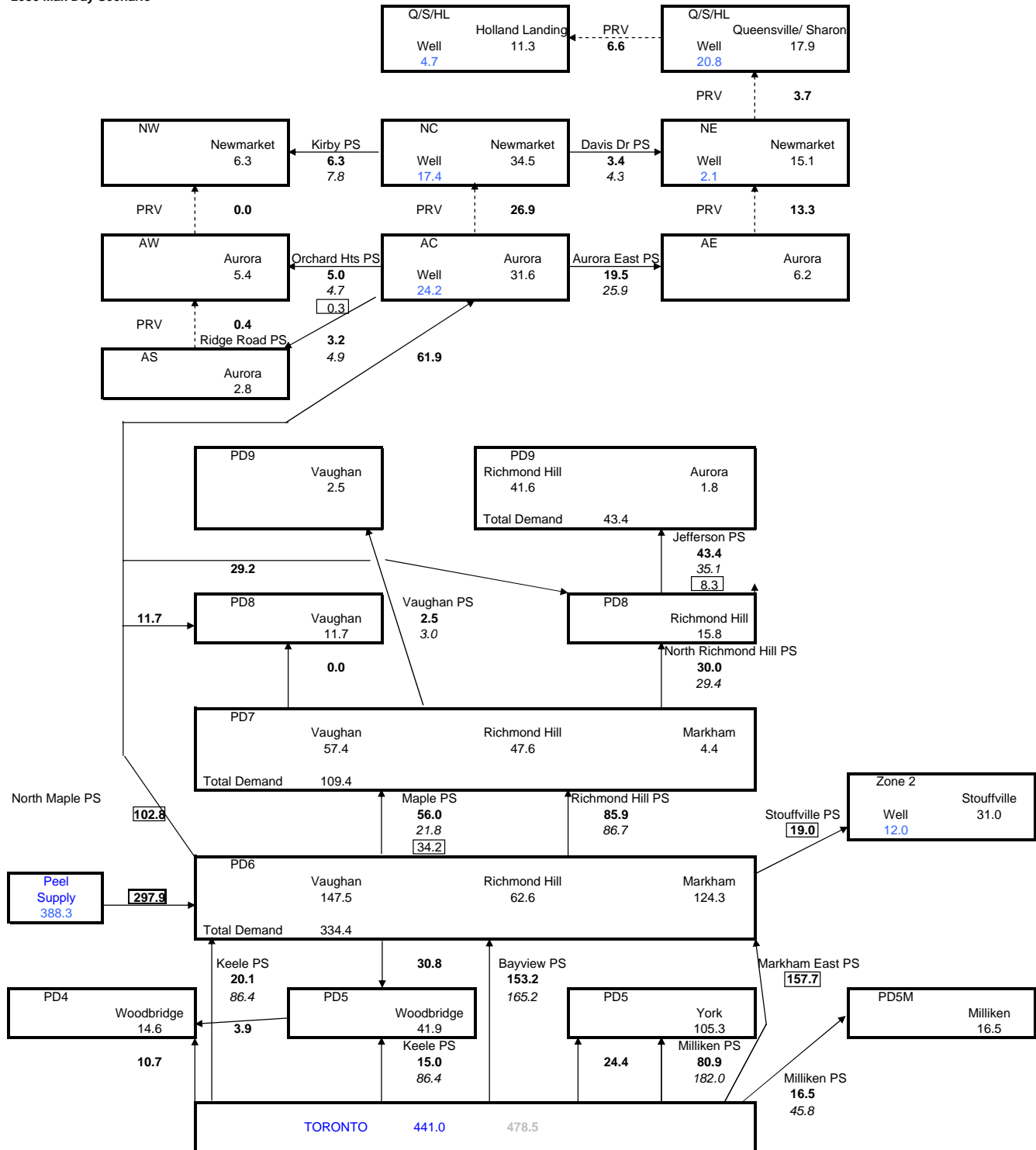

Numbers in italics - current pumping station capacities
Numbers in box - pumping station capacity upgrade required